



TOUCH PROGRAMMABLE RESOLVER LIMIT SWITCH (PRLS)

Hardware User Manual

(Manual Part Number MAN-TPRLS-001)

WARNING!

Programmable control devices such as the Touch PRLS must not be used as stand-alone protection in any application. Unless proper safeguards are used, unwanted start-ups could result in equipment damage or personal injury. The operator must be made aware of this hazard and appropriate precautions must be taken.

In addition, consideration must be given to the use of an emergency stop function that is independent of the programmable controller.

The diagrams and examples in this user manual are included for illustrative purposes only. The manufacturer cannot assume responsibility or liability for actual use based on the diagrams and examples.

WARNING: If the Touch PRLS is used in a CLASS I, DIV. 2 environment, the following conditions must be met: Class I, Div. 2 methods; AND — must conform to all rules and requirements of applicable jurisdictions regarding Class I, Div. 2 installations; ALSO — peripheral equipment controlling this device or being controlled by it shall be suitable for service in the location in which they are used. **Failure to comply with any of the above installation requirements will invalidate the device's qualifications for service in CLASS I, DIV. 2 hazardous locations.**

WARNING: EXPLOSION HAZARD — SUBSTITUTION OF COMPONENTS MAY IMPAIR SUITABILITY FOR CLASS I, DIVISION 2.

WARNING: EXPLOSION HAZARD — DO NOT DISCONNECT EQUIPMENT UNLESS POWER HAS BEEN SWITCHED OFF OR THE AREA IS KNOWN TO BE NON-HAZARDOUS.

CAUTION

Do not press the Touch PRLS touchscreen with any sharp objects. This practice may damage the unit beyond repair.

Trademarks

This publication may contain references to products produced and/or offered by other companies. The product and company names may be trademarked and are the sole property of their respective owners. UTICOR Technology, L. P. disclaims any proprietary interest in the marks and names of others.

© Copyright 2003, UTICOR Technology, L.P.
All Rights Reserved

No part of this manual shall be copied, reproduced, or transmitted in any way without the prior written consent of UTICOR Technology, L.P. UTICOR Technology, L.P. retains the exclusive rights to all information included in this document.

Manual P/N MAN-TPRLS-001

Touch PRLS

MANUFACTURED and MARKETED by



UTICOR TECHNOLOGY, L. P.

4140 Utica Ridge Rd. • Bettendorf, IA 52722-1327



Contents

WARNING/Caution/Trademarks/Copyright	inside front cover
Contents	i
Introduction	1
What you need to get started	2
Hardware	2
Software	2
Need Help?	2
Onscreen HELP	2
Fly-Over HELP	2
Technical Support	3
Specifications	5
I/O Electrical Specifications	6
Touch PRLS Input/Output (I/O) Card Outline Drawing	7
Touch PRLS Processor Card Outline Drawing	8
Touch PRLS Connector Location in the Panel	
Back View	9
Bottom View	9
Resolver Wiring Diagram — Touch PRLS with 32 Outputs	10

Touch PRLS™



This page intentionally left blank.



Introduction

This manual provides you with the information particular to the Touch PRLS and will be used to supplement information provided in the PowerPanel Hardware Manual (MAN-UTICW-001) that was also shipped with your Touch PRLS. The Touch PRLS is essentially a PowerPanel with a Touch PRLS processor card and an I/O card installed.



You will configure the TPRLS with the Touch PRLS Programming Software . This software is an executable file (Touch_PRLS.exe) that can be found in the PowerPanel Programming Software Program folder (this is installed by default to: C:\Program Files\PowerPanel\) that was created when you installed the software on your programming computer. For more information, please refer to the **PowerPanel Programming Software User Manual**.

Also included on the PowerPanel Programming Software CD, you will find the Touch PRLS Programming Software User Manual (P/N MAN-TPRLS-002) as a .pdf file (portable document file) to view online or print out for easy reference.

These manuals will take you through the steps necessary to get your Touch PRLS up and running in the shortest possible time. Although your familiarity with programmable graphic operator interface devices will determine how quickly you move through the steps — it's as easy as 1 — 2 — 3.

When creating a program for your motion control application, you will create screens for the Touch PRLS that will provide a graphical interface designed to interchange and display data from a PLC and the TPRLS option cards by merely viewing or touching the screen — all unique to your particular application. For instructions on how to design screens, refer to the **PowerPanel Programming Software User Manual**.

What you need to get started:

Hardware

- Touch PRLS Series (6", 8", 10", or 15" Color unit)
- 24 Volt Power Supply
- RS-232C Programming Cable (P/N CBL-UTICW-009)
- TPRLS to Resolver Cables: CBL-TPRLS-005 (5 ft.), CBL-TPRLS-010 (10 ft.), CBL-TPRLS-015 (15 ft.), or CBL-TPRLS-020 (20 ft.)
- Resolver, such as AVG's RL100, E5R, E7R, or E8R Series
- TPRLS I/O D-sub Cable (P/N CBL-TPRLS-I/O3)
- PLC and PLC Cable (see PowerPanel Hardware Manual)
- PC requirements:
 - IBM or compatible PC (486 or better) with a mouse, keyboard and separate serial port
 - VGA display with at least 800 x 600 resolution (1024 x 768 recommended)
 - Standard Windows 98/NT4.0/ME/2000/XP® Requirements
 - CD ROM Drive

Software

- PowerPanel Programming Software, Version 4.0 or higher
- Touch PRLS Programming Software (P/N ACC-TPRLS-EDIT) (included on the CD that was shipped with the unit)

Need HELP?



Help is never more than a mouse click or a key press away!

Onscreen HELP

One of the most important features of the Touch PRLS Programming Software is the availability of context sensitive onscreen help. To access the Help windows, simply press the F1 function key while on the topic where you need help. For example, if you need help while working with screens, hit the F1 function key while in that area and a popup window will be displayed. Also, most dialog boxes contain a Help button, you may click on it to get help, too!

Fly-Over HELP

When the mouse cursor comes to rest over any tool bar or object button for a short while, a small window will appear containing a brief description of the function of that particular button. The window will disappear as soon as the cursor has been moved off the button.



Technical Support

Although most questions can be answered with Touch PRLS Programming Software HELP topics or the manuals, if you are still having difficulty with a particular aspect of installation or configuration, technical support is available at **1-800-TEC-ENGR (832-3647)** or **FAX us at 1-563-359-9094**. Visit our website at ***www.uticor.net***.

Touch PRLS™



This page intentionally left blank.



Specifications

Position Resolution: 1 in 4096

Position Accuracy: 1 in 2160

Update Time: 26 µSec

Programmable Parameters:

Scale Factor

Position Offset

On/Off Setpoints

Setups (Programs)

Speed Compensation

Motion Limits: High and Lo (RPM)

Scale Factor: Programmable from 1 to 4096, common to all PLS setup

Position Offset: Programmable to full scale factor value, common to all PLS setup

Number of PLS On / Off Set points: up to 256 per PLS setup

Number of PLS Programs in a Project: limited by user memory (123 KB)

Speed Compensation: Programmable in msec. Each PLS output (channel) has its own leading and trailing edge speed compensation

Motion Detector: Low and High motion limits, common to all PLS setups, programmable from 0 to 1023 RPM

Number of PLS outputs: 32 total (16 Hard Cams, 8 with Timer + 16 Soft Cams)

ModZ Input: Modification to Zero on the fly with an external input (edge triggered); 3 ModZ inputs

Program Enable Input: when active program changes can be made

Output Enable Input : to enable outputs this input must be active

Serial Communication: pass through Touch PRLS panel or RS-232 connector on the card

Broken Resolver Wire Detection: indication for broken wire in I/O Status

Discrete (hard-wired) Outputs/Inputs Operation (*On = Logic True, Off = Logic False*)

PLS Outputs

On = if current position is within the dwell (on/off setpoint)

Off = if current position is outside the dwell (on/off setpoint)

PE (Program Enable) Input

On = Programming Enabled

Off = Programming Disabled

I/O Electrical Specifications

I/O Power Input: 24 VDC Nominal (16-32 VDC) @ 100 mA + user loads.

Customer supplied: 24 VDC Power VS+, VS-; 16 to 32 VDC @ 100 mA plus current used by user's loads and inputs.

To maintain optical isolation, I/O power should be separate from Service Power

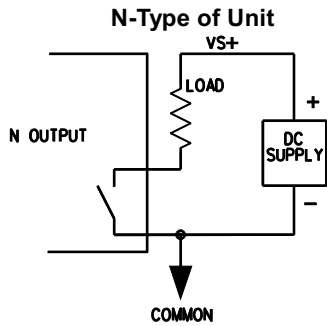
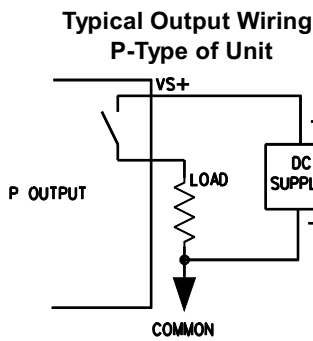

N-TYPE UNIT (SINKING)

Output Logic Levels:
Logic True: MOSFET On, 0.2 V Max. @ 100 mA
Logic False: MOSFET Off, 0.05 mA leakage @ 30V
Max. Current per Output: 600 mA
Max. Current per Card (all Outputs): 2 A
Output Isolation: 1,500 V

Input Logic Levels:
Logic True: 16–32 VDC
Logic False: 0–6 VDC
Input Isolation: 1,500 V

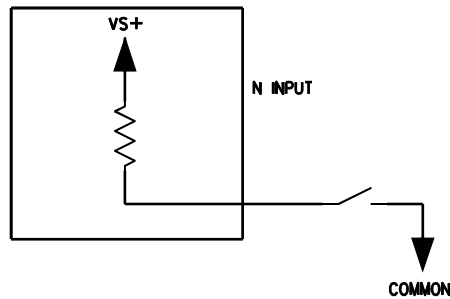
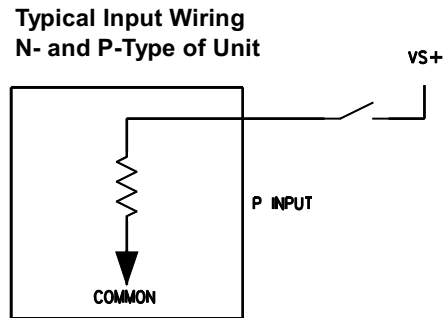

P-TYPE UNIT (SOURCING)

Output Logic Levels:
Logic True: MOSFET On, 0.5 V Drop @ 100 mA
Logic False: MOSFET Off, 0.05 mA leakage @ 30V
Max. Current per Output: 600 mA
Max. Current per Card (all Outputs): 2 A
Output Isolation: 1,500 V

Input Logic Levels:
Logic True: 16–32 VDC
Logic False: 0–6 VDC
Input Isolation: 1,500 V

Touch PRLS Input/Output (I/O) Card Outline Drawing

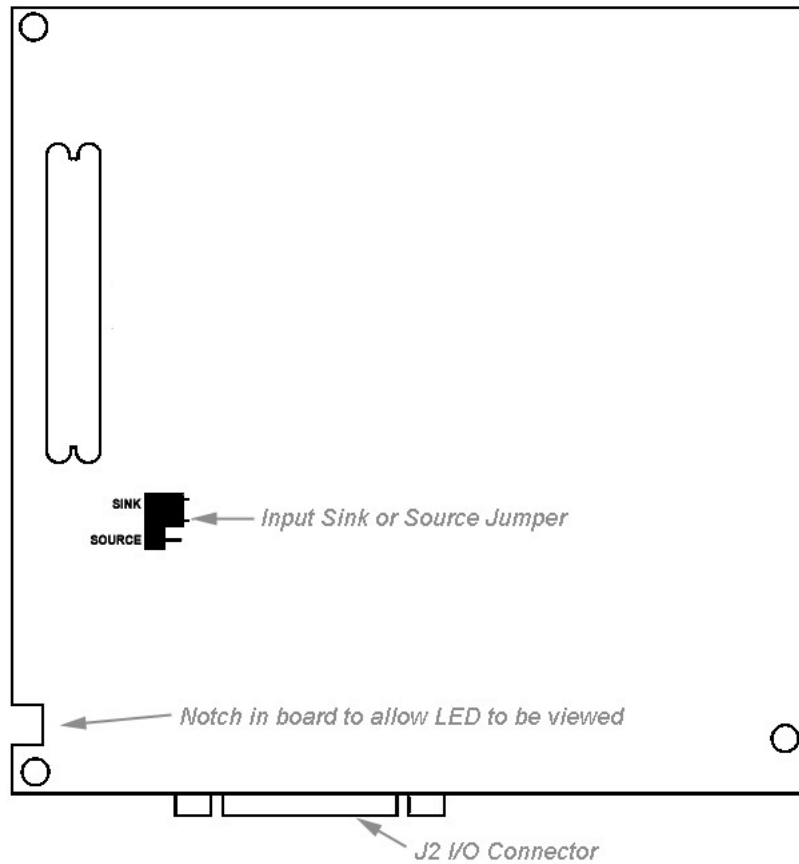

The input sink or source jumper is factory set to sink. You can access the I/O Card by opening the back cover of the panel. Use cable P/N CBL-TPRLS-I/O3 to connect to J2 I/O connector.

Touch PRLS Processor Card Outline Drawing

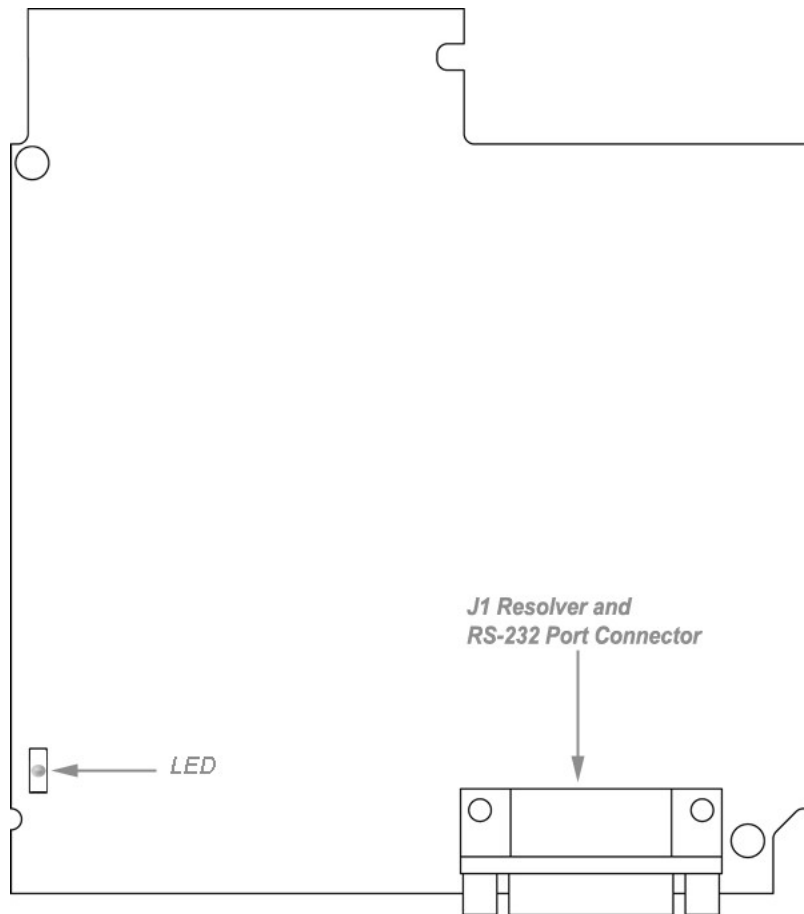

LED: The processor board LED will illuminate faint green to indicate normal operation. If the LED illuminates solid Orange this indicates that the outputs are disabled. The LED is visible only when the rear cover of the panel is open.

J-1: J-1 connects to resolver and RS-232 is used for firmware updates.

Use cable P/Ns CBL-TPRLS-005 (5 ft.), CBL-TPRLS-010 (10 ft.), CBL-TPRLS-015 (15 ft.), or CBL-TPRLS-020 (20 ft.) to connect J1 Connector to resolver.

Touch PRLS Connector Location in the Panel

On the bottom of the Touch PRLS unit you will find two female D-sub connectors, J1 and J2, as shown below. All resolver, PLS Control Inputs and PLS Outputs connections are made here.

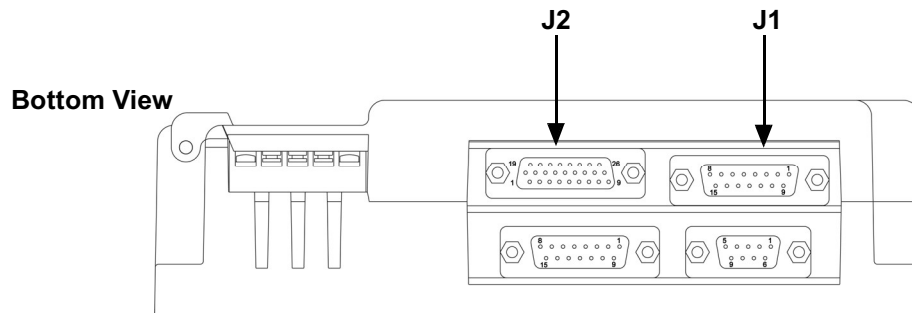
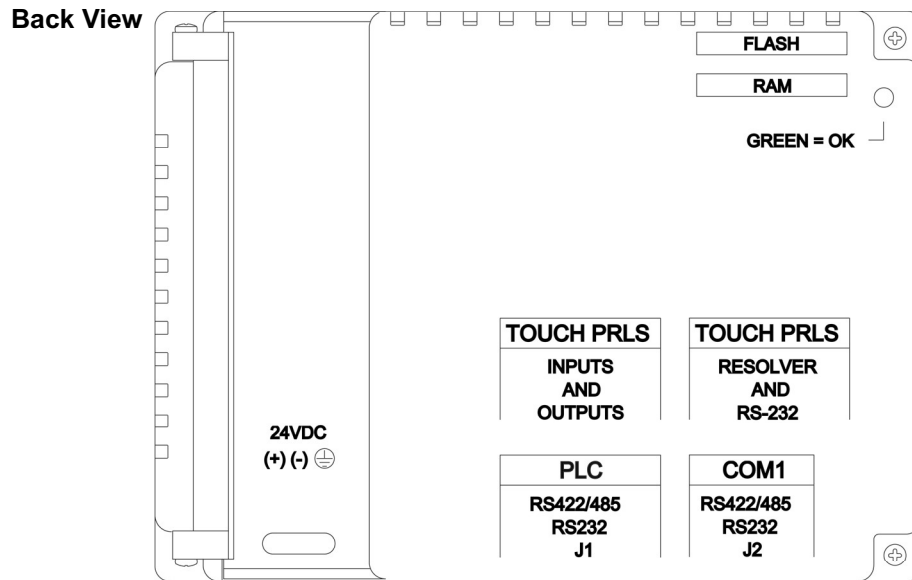

Resolver Wiring Diagram — Touch PRLS with 32 Outputs

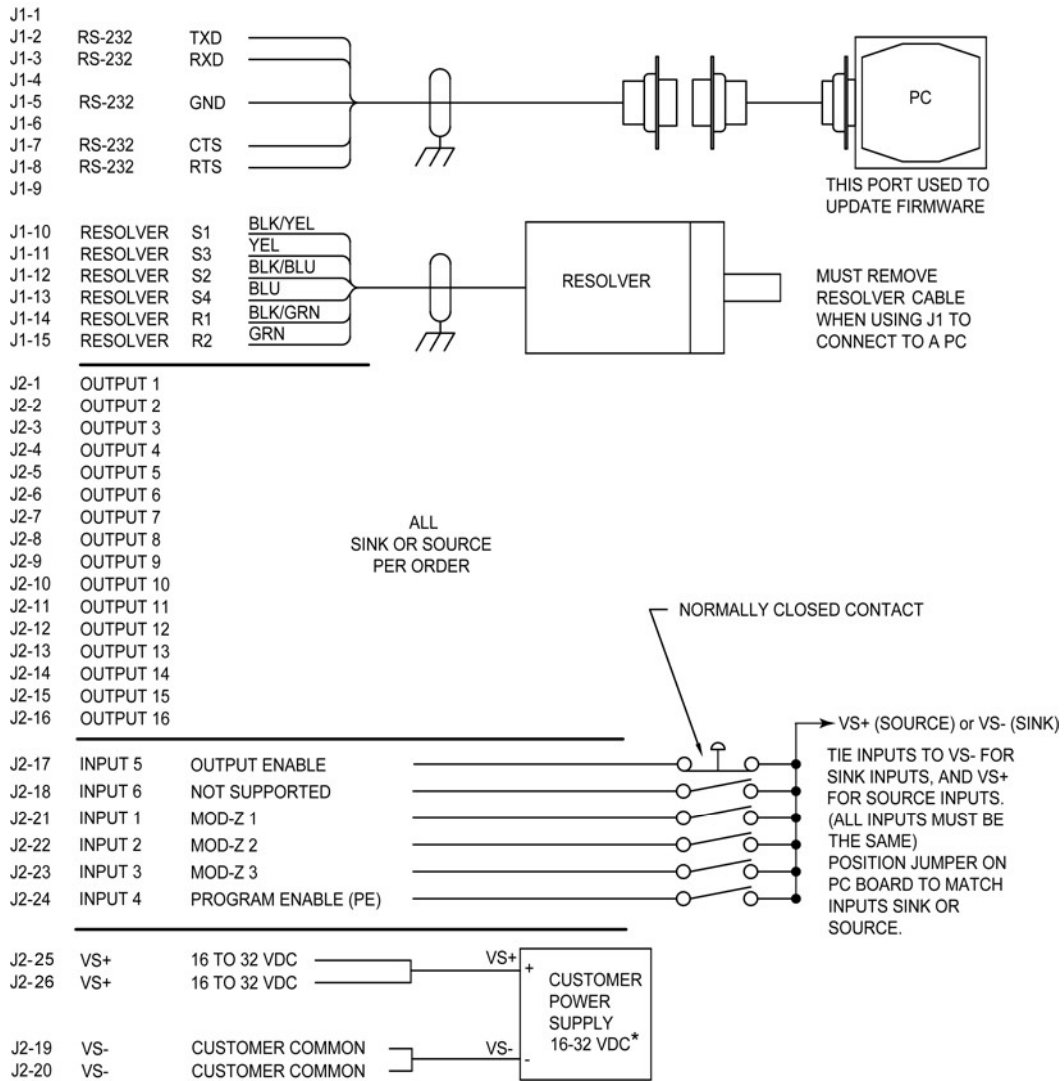

* Note: Customer Power Supply MUST be isolated from Panel Power Supply